

ABWC472SS  
**24" DUAL ZONE WINE CELLAR**  
**STAINLESS STEEL**

**AVIVA**



**CONTROLS AND FUNCTIONS**

Product type	Dual Zone Wine cellar
Temperature zone(s)	Upper Zone: 5-10°C (41-50°F) Lower Zone: 10-18°C (50-64°F)
Configuration	Single door
Controls	Electronic touch controls with Blue LED display
Interior lighting	4-level Blue LED lighting on top
Door open alarm	Yes
High-temperature alarm	Yes
Multi-sensor precision temperature control	Yes
Fan-assisted cooling	Yes
Vibration-dampening mounts	Yes
Sabbath mode	Yes

**SPECIFICATIONS AND DIMENSIONS**

Dimensions	23 7/16"(W) x 23 1/4"(D) x 34 1/4"(H)
Sound level	39 dBA
Capacity	46 bottles (750-ml)
Shelves	5 ball-bearing, full-extension, soft-close wood racks with stainless front
Door & hinge	Field-reversible door with articulated hinge
Door frame	Seamless 304-grade stainless steel
Glass door	Triple-pane with Low-e argon gas
Door lock	No
Handle	Tubular pro
Kickplate	Stainless steel
Cabinet color	Black
Air filtration	Yes - with carbon filter
Installation	Built-in or freestanding
Refrigerant	R600a
Compressor	Embraco
Electrical requirements	115V / 60Hz / 1.25A
Warranty	2 years parts and labor, 5 years sealed system (parts only)
UPC Code	628173081598

# ABWC472SS 24" DUAL ZONE WINE CELLAR STAINLESS STEEL

# AVIVA

## DIMENSIONS & INSTALLATION

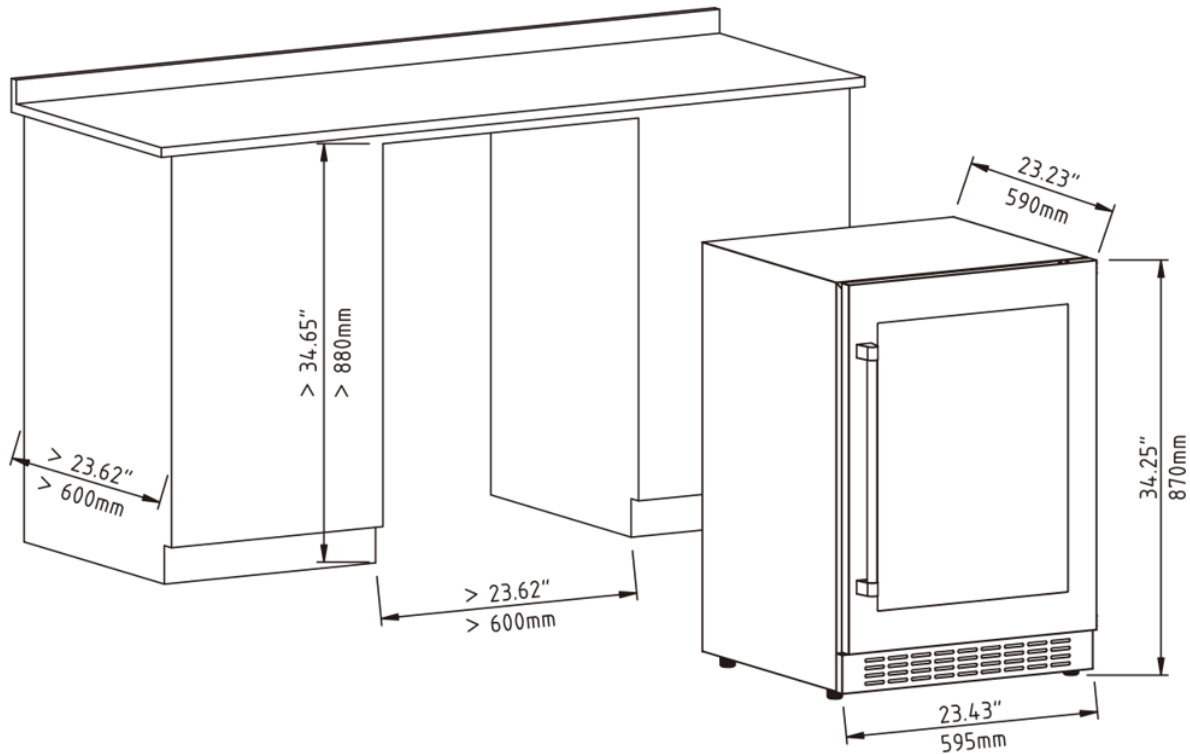

Note: If the appliance is fully built in and installed with a kitchen plinth, ensure that the ventilation openings in the plinth provide at least 300 cm<sup>2</sup> of free airflow. Remove any ventilation grilles so that hot air can disperse without obstruction. Otherwise, the appliance will operate under higher strain, leading to increased energy consumption.

## LOADING CAPACITY

